

KLM8G1GESD  
KLMAG2GESD  
KLMBG4GESD  
KLMCG8GESD

Automotive

# Samsung eMMC Product family

eMMC 5.0 Specification compatibility

## datasheet

SAMSUNG ELECTRONICS RESERVES THE RIGHT TO CHANGE PRODUCTS, INFORMATION AND SPECIFICATIONS WITHOUT NOTICE.

Products and specifications discussed herein are for reference purposes only. All information discussed herein is provided on an "AS IS" basis, without warranties of any kind.

This document and all information discussed herein remain the sole and exclusive property of Samsung Electronics. No license of any patent, copyright, mask work, trademark or any other intellectual property right is granted by one party to the other party under this document, by implication, estoppel or otherwise.

Samsung products are not intended for use in life support, critical care, medical, safety equipment, or similar applications where product failure could result in loss of life or personal or physical harm, or any military or defense application, or any governmental procurement to which special terms or provisions may apply.

For updates or additional information about Samsung products, contact your nearest Samsung office.

All brand names, trademarks and registered trademarks belong to their respective owners.

© 2015 Samsung Electronics Co., Ltd. All rights reserved.

## Revision History

<u>Revision No.</u>	<u>History</u>	<u>Draft Date</u>	<u>Remark</u>	<u>Edited by</u>	<u>Reviewed by</u>
0.5	1. Engineering Sample	Jan. 28, 2015	Preliminary	S.M.Lee	-
1.0	1. Customer Sample 2. Ball-out revision 3. Density(64 GB_KLMCG8GESD-B03x) added.	May. 07, 2015	Final	S.M.Lee H.K.Kim	J.H.Cheon
1.0.1	1. Typo corrected.	May. 12, 2015	Final	H.K.Kim	J.H.Cheon

**Table Of Contents**

1.0 PRODUCT LIST ..... 4

2.0 KEY FEATURES ..... 4

3.0 PACKAGE CONFIGURATIONS ..... 5

    3.1 153 Ball Pin Configuration ..... 5

        3.1.1 11.5mm x 13mm x 0.8mm Package Dimension ..... 6

        3.1.2 11.5mm x 13mm x 1.0mm Package Dimension ..... 6

    3.2 Product Architecture ..... 7

4.0 eMMC 5.0 feature ..... 8

    4.1 HS400 mode ..... 8

5.0 Technical Notes ..... 9

    5.1 S/W Algorithm ..... 9

        5.1.1 Partition Management ..... 9

            5.1.1.1 Enhanced Partition (Area) ..... 9

        5.1.2 Boot operation ..... 9

        5.1.3 User Density ..... 10

        5.1.4 Auto Power Saving Mode ..... 10

        5.1.5 Performance ..... 11

6.0 REGISTER VALUE ..... 12

    6.1 OCR Register ..... 12

    6.2 CID Register ..... 12

        6.2.1 Product name table (In CID Register) ..... 12

    6.3 CSD Register ..... 13

    6.4 Extended CSD Register ..... 14

7.0 AC PARAMETER ..... 18

    7.1 Timing Parameter ..... 18

    7.2 Previous Bus Timing Parameters for DDR52 and HS200 mode are defined by JEDEC standard ..... 18

    7.3 Bus Timing Specification in HS400 mode ..... 19

        7.3.1 HS400 Device Input Timing ..... 19

        7.3.2 HS400 Device Output Timing ..... 20

    7.4 Bus signal levels ..... 21

        7.4.1 Open-drain mode bus signal level ..... 21

        7.4.2 Push-pull mode bus signal level eMMC ..... 21

8.0 DC PARAMETER ..... 22

    8.1 Active Power Consumption during operation ..... 22

    8.2 Standby Power Consumption in auto power saving mode and standby state ..... 22

    8.3 Sleep Power Consumption in Sleep State ..... 22

    8.4 Supply Voltage ..... 22

    8.5 Bus Signal Line Load ..... 23

**IF THERE IS ANY OTHER OPERATION TO IMPLEMENT IN ADDITION TO SPECIFICATION IN THE DATASHEET OR JEDEC STANDARD, PLEASE CONTACT EACH BRANCH OFFICE OR HEADQUARTERS OF SAMSUNG ELECTRONICS.**



## INTRODUCTION

SAMSUNG eMMC is an embedded MMC solution designed in a BGA package form. eMMC operation is identical to a MMC device and therefore is a simple read and write to memory using MMC protocol v5.0 which is a industry standard.

eMMC consists of NAND flash and a MMC controller. 3V supply voltage is required for the NAND area (VDDF or VCC) whereas 1.8V or 3V dual supply voltage (VDD or VCCQ) is supported for the MMC controller. SAMSUNG eMMC supports HS400 in order to improve sequential bandwidth, especially sequential read performance.

There are several advantages of using eMMC. It is easy to use as the MMC interface allows easy integration with any microprocessor with MMC host. Any revision or amendment of NAND is invisible to the host as the emhghbedded MMC controller insulates NAND technology from the host. This leads to faster product development as well as faster times to market.

The embedded flash management software or FTL(Flash Transition Layer) of eMMC manages Wear Leveling, Bad Block Management and ECC. The FTL supports all features of the Samsung NAND flash and achieves optimal performance.

## 1.0 PRODUCT LIST

[Table 1] Product List

Capacities	eMMC Part ID	NAND Flash Type	User Density(%)	Power System	Package size	Pin Configuration
8 GB	KLM8G1GESD-B03x	64 Gb MLC x 1	91.0 %	- Interface power : VDD (1.70 V ~ 1.95 V or 2.7 V ~ 3.6 V) - Memory power : VDDF (2.7 V ~ 3.6 V)	11.5 mm x 13 mm x 0.8 mm	153 FBGA
16 GB	KLMAG2GESD-B03x	64 Gb MLC x 2				
32 GB	KLMBG4GESD-B03x	64 Gb MLC x 4				
64 GB	KLMCG8GESD-B03x	64 Gb MLC x 8			11.5 mm x 13 mm x 1.0 mm	

## 2.0 KEY FEATURES

- AEC-Q100
- Embedded MultiMediaCard Ver. 5.0 compatible. Detail description is referenced by JEDEC Standard
- SAMSUNG eMMC supports features of eMMC5.0 which are defined in JEDEC Standard
  - Supported Features : Packed command, Cache, Discard, Sanitize, Power Off Notification, Data Tag, Partition types, Context ID, Real Time Clock, Dynamic Device Capacity, HS200
  - Non-supported Features : Large Sector Size (4KB)
- Additional feature : HS400 mode (200MHz DDR)
- Full backward compatibility with previous MultiMediaCard system specification (1bit data bus, multi-eMMC systems)
- Data bus width : 1bit (Default), 4bit and 8bit
- MMC I/F Clock Frequency : 0 ~ 200MHz  
MMC I/F Boot Frequency : 0 ~ 52MHz
- Support Automotive Temperature ( -40 °C ~ 85 °C / 105 °C)
  - 15<sup>th</sup> digit stands for below
    - P : -40 °C ≤ T<sub>A</sub> ≤ 85 °C
    - Q : -40 °C ≤ T<sub>A</sub> ≤ 105 °C
- Power : Interface power → VDD(VCCQ) (1.70V ~ 1.95V or 2.7V ~ 3.6V) , Memory power → VDDF(VCC) (2.7V ~ 3.6V)

**IF THERE IS ANY OTHER OPERATION TO IMPLEMENT IN ADDITION TO SPECIFICATION IN THE DATASHEET OR JEDEC STANDARD, PLEASE CONTACT EACH BRANCH OFFICE OR HEADQUARTERS OF SAMSUNG ELECTRONICS.**



3.1.1 11.5mm x 13mm x 0.8mm Package Dimension

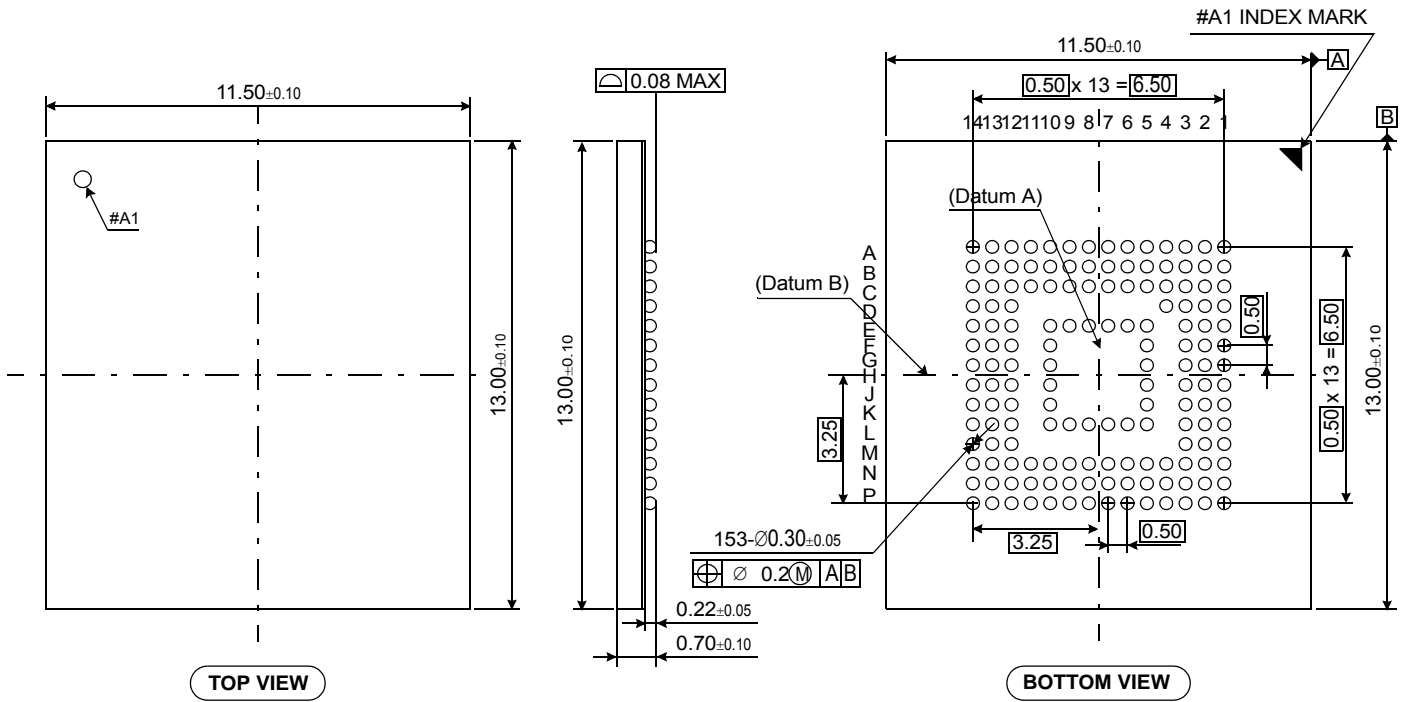

[Figure 2] 11.5mm x 13mm x 0.8mm Package Dimension

3.1.2 11.5mm x 13mm x 1.0mm Package Dimension

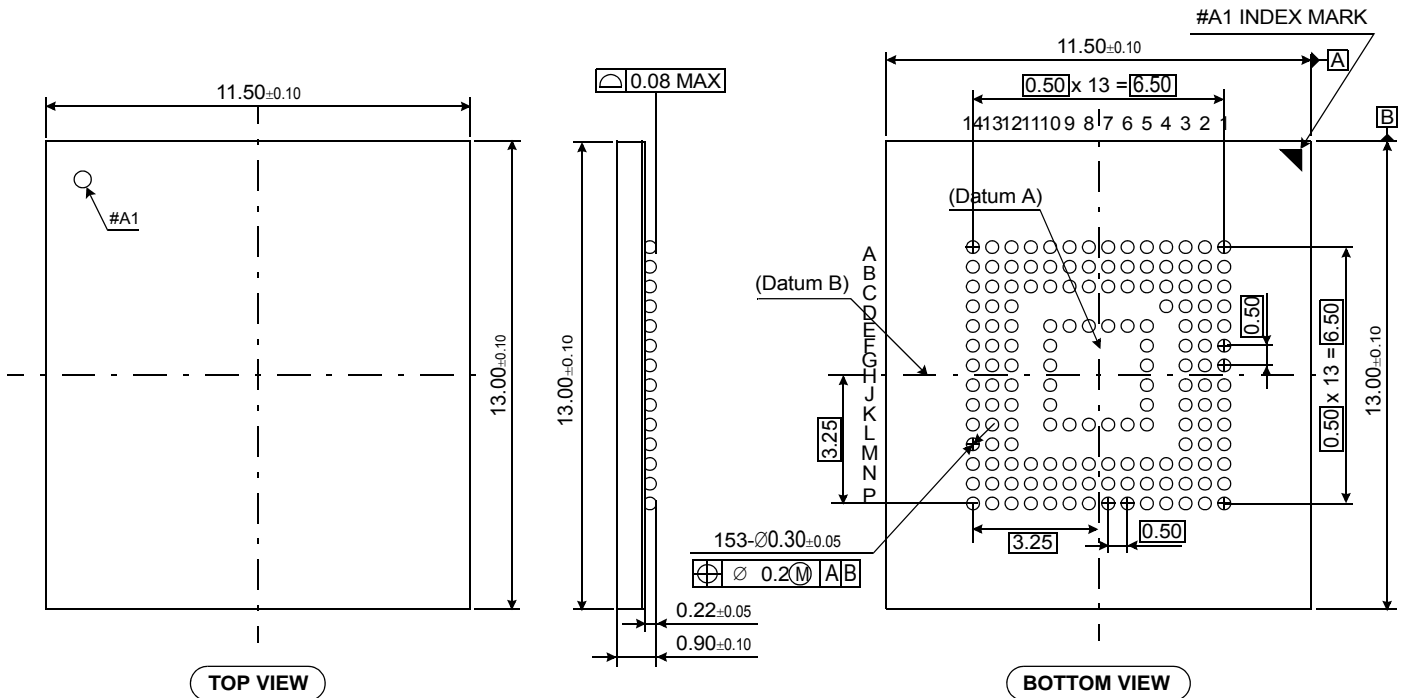

[Figure 3] 11.5mm x 13mm x 1.0mm Package Dimension

IF THERE IS ANY OTHER OPERATION TO IMPLEMENT IN ADDITION TO SPECIFICATION IN THE DATASHEET OR JEDEC STANDARD, PLEASE CONTACT EACH BRANCH OFFICE OR HEADQUARTERS OF SAMSUNG ELECTRONICS.

### 3.2 Product Architecture

- eMMC consists of NAND Flash and Controller.  $V_{DD}$  ( $V_{CCQ}$ ) is for Controller power and  $V_{DDF}$  ( $V_{CC}$ ) is for flash power

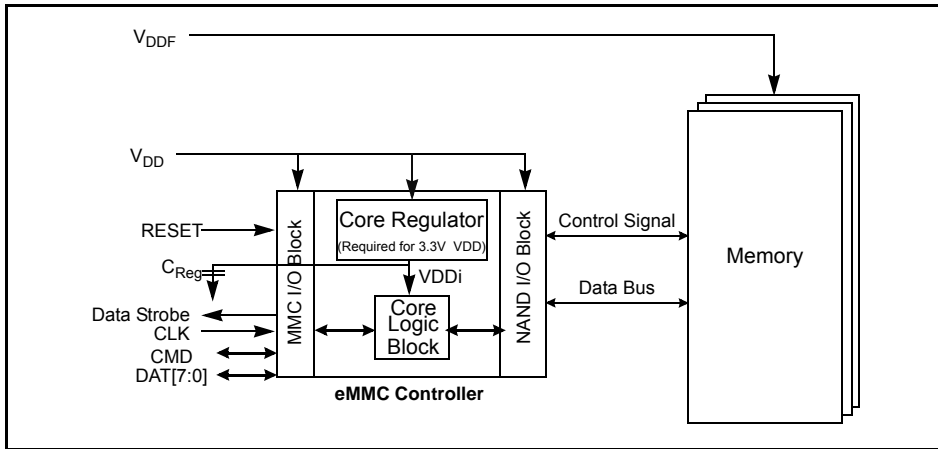

[Figure 4] eMMC Block Diagram

IF THERE IS ANY OTHER OPERATION TO IMPLEMENT IN ADDITION TO SPECIFICATION IN THE DATASHEET OR JEDEC STANDARD, PLEASE CONTACT EACH BRANCH OFFICE OR HEADQUARTERS OF SAMSUNG ELECTRONICS.

## 4.0 eMMC 5.0 feature

### 4.1 HS400 mode

eMMC5.0 product supports high speed DDR interface timing mode up to 400MB/s with 1.8V I/O supply.

HS400 mode supports the following features :

- DDR Data sampling method
- CLK frequency up to HS400
- Only 8-bits bus width available
- Signaling levels of 1.8V
- Six selectable Drive Strength (refer to the table below)

[Table 3] I/O driver strength types

Driver Type	HS200 & HS400 Support	Nominal Impedance	Approximated driving capability compared to Type-0	Remark
0	Default	50Ω	x1	Default Driver Type. Supports up to 200MHz operation.
1	Optional	33Ω	x1.5	Supports up to 200MHz Operation.
2	Optional	66Ω	x0.75	The weakest driver that supports up to 200MHz operation.
3	Optional	100Ω	x0.5	For low noise and low EMI systems. Maximal operating frequency is decided by Host design.
4	Optional	40Ω	x1.2	Supports up to 200MHz DDR operation

**NOTE :**

1) Support of Driver Type-0 is default for HS200 & HS400 Device, while supporting Driver types 1~5 are optional for HS200 & HS400 Device.

[Table 4] Device type values (EXT\_CSD register : DEVICE\_TYPE [196])

Bit	Device Type	Supportability
7	HS400 Dual Data Rate eMMC @ 200 MHz - 1.2V I/O	Not support
6	HS400 Dual Data Rate eMMC @ 200 MHz - 1.8V I/O	Support
5	HS200 Single Data Rate eMMC @ 200 MHz - 1.2V I/O	Not support
4	HS200 Single Data Rate eMMC @ 200 MHz - 1.8V I/O	Support
3	High-Speed Dual Data Rate eMMC @ 52MHz - 1.2V I/O	Not support
2	High-Speed Dual Data Rate eMMC @ 52MHz - 1.8V or 3V I/O	Support
1	High-Speed eMMC @ 52MHz - at rated device voltage(s)	Support
0	High-Speed eMMC @ 26MHz - at rated device voltage(s)	Support

[Table 5] Extended CSD revisions (EXT\_CSD register : EXT\_CSD\_REV [192])

Value	Timing Interface	EXT_CSD Register Value
255-8	Reserved	-
7	Revision 1.7 (for MMC V5.0)	0x07
6	Revision 1.6 (for MMC V4.5, V4.51)	-
5	Revision 1.5 (for MMC V4.41)	-
4	Revision 1.4 (Obsolete)	-
3	Revision 1.3 (for MMC V4.3)	-
2	Revision 1.2 (for MMC V4.2)	-
1	Revision 1.1 (for MMC V4.1)	-
0	Revision 1.0 (for MMC V4.0)	-

[Table 6] High speed timing values (EXT\_CSD register : HS\_TIMING [185])

Value	Timing Interface	Supportability
0x0	Selecting backwards compatibility interface timing	Support
0x1	High Speed	Support
0x2	HS200	Support
0x3	HS400	Support

**IF THERE IS ANY OTHER OPERATION TO IMPLEMENT IN ADDITION TO SPECIFICATION IN THE DATASHEET OR JEDEC STANDARD, PLEASE CONTACT EACH BRANCH OFFICE OR HEADQUARTERS OF SAMSUNG ELECTRONICS.**



## 5.0 Technical Notes

### 5.1 S/W Algorithm

#### 5.1.1 Partition Management

The device initially consists of two Boot Partitions and RPMB Partition and User Data Area.

The User Data Area can be divided into four General Purpose Area Partitions and User Data Area partition. Each of the General Purpose Area partitions and a section of User Data Area partition can be configured as enhanced partition.

##### 5.1.1.1 Enhanced Partition (Area)

SAMSUNG eMMC adopts Enhanced User Data Area as SLC Mode. Therefore when master adopts some portion as enhanced user data area in User Data Area, that area occupies double size of original set up size. ( ex> if master set 1MB for enhanced mode, total 2MB user data area is needed to generate 1MB enhanced area)

Max Enhanced User Data Area size is defined as (MAX\_ENH\_SIZE\_MULT x HC\_WP\_GRP\_SIZE x HC\_ERASE\_GRP\_SIZE x 512kBytes)

#### 5.1.2 Boot operation

Device supports not only boot mode but also alternative boot mode. Device supports high speed timing and dual data rate during boot.

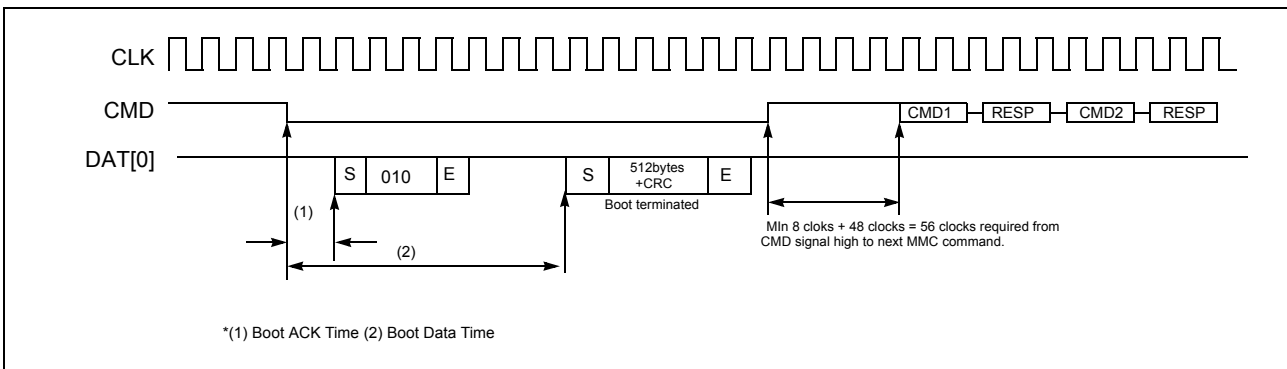

[Figure 5] embedded MultiMediaCard state diagram (boot mode)

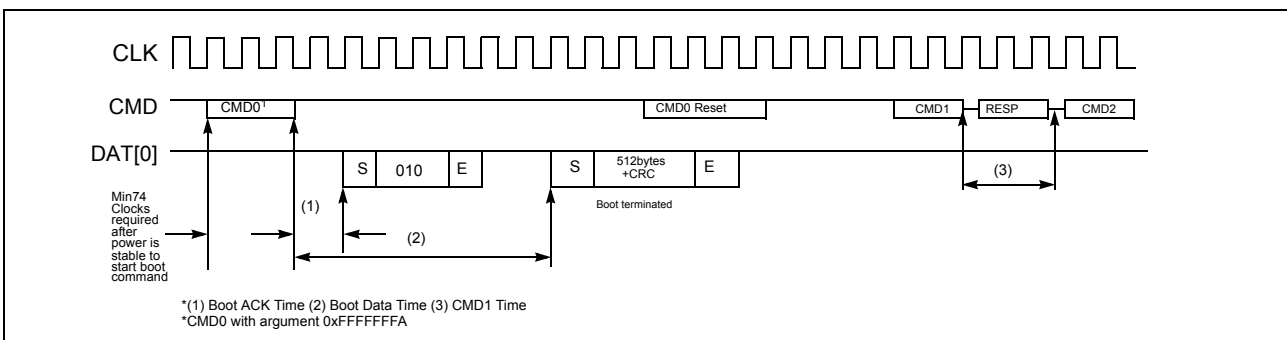

[Figure 6] embedded MultiMediaCard state diagram (alternative boot mode)

[Table 7] Boot ack, boot data and initialization Time

Timing Factor	Value
(1) Boot ACK Time	< 20 ms
(2) Boot Data Time	< 20 ms
(3) Initialization Time <sup>1)</sup>	< 200ms

**NOTE :**

1) This initialization time includes partition setting, Please refer to INI\_TIMEOUT\_AP in 6.4 Extended CSD Register. Normal initialization time (without partition setting) is completed within 1sec

**IF THERE IS ANY OTHER OPERATION TO IMPLEMENT IN ADDITION TO SPECIFICATION IN THE DATASHEET OR JEDEC STANDARD, PLEASE CONTACT EACH BRANCH OFFICE OR HEADQUARTERS OF SAMSUNG ELECTRONICS.**

### 5.1.3 User Density

Total User Density depends on device type. For example, 32MB in the SLC Mode requires 64MB in MLC. This results in decreasing of user density

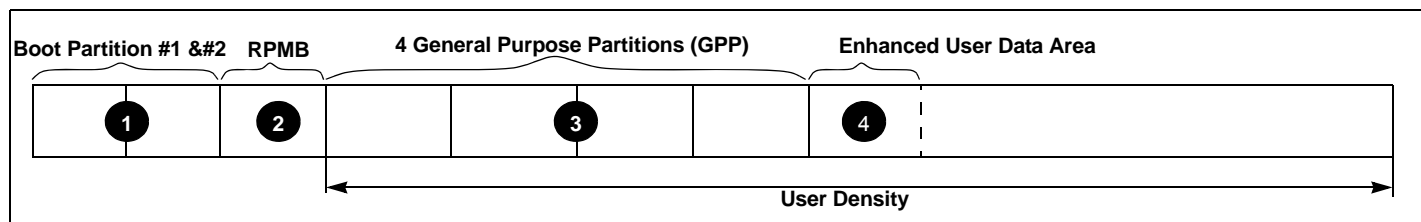

[Table 8] Capacity according to partition

		Boot partition 1	Boot partition 2	RPMB
8 GB	Default.	16,384 KB	16,384 KB	512 KB
	Max.	16,384 KB	16,384 KB	4,096 KB
16 GB, 32 GB, 64 GB	Default.	16,384 KB	16,384 KB	4,096 KB
	Max.	16,384 KB	16,384 KB	4,096 KB

[Table 9] Maximum Enhanced Partition Size

Device	Max. Enhanced Partition Size
8 GB	3,909,091,328
16 GB	7,809,794,048
32 GB	15,627,976,704
64 GB	31,264,342,016

[Table 10] User Density Size

Device	User Density Size
8 GB	7,818,182,656
16 GB	15,634,268,160
32 GB	31,268,536,320
64 GB	62,537,072,640

### 5.1.4 Auto Power Saving Mode

If host does not issue any command during a certain duration (1ms), after previously issued command is completed, the device enters "Power Saving mode" to reduce power consumption.

At this time, commands arriving at the device while it is in power saving mode will be serviced in normal fashion

[Table 11] Auto Power Saving Mode enter and exit

Mode	Enter Condition	Escape Condition
Auto Power Saving Mode	When previous operation which came from Host is completed and no command is issued during a certain time.	If Host issues any command

[Table 12] Auto Power Saving Mode and Sleep Mode

	Auto Power Saving Mode	Sleep Mode
NAND Power	ON	OFF
GotoSleep Time	< 1ms	< 1ms

IF THERE IS ANY OTHER OPERATION TO IMPLEMENT IN ADDITION TO SPECIFICATION IN THE DATASHEET OR JEDEC STANDARD, PLEASE CONTACT EACH BRANCH OFFICE OR HEADQUARTERS OF SAMSUNG ELECTRONICS.

5.1.5 Performance

[Table 13] Performance

Density	Sequential Read (MB/s)	Sequential Write (MB/s)
8 GB	160	25
16 GB	230	50
32 GB	250	100
64 GB		

\* Test Condition : Bus width x8, HS400, 512KB data transfer, Packed Off, Cache On, w/o file system overhead, measured on Samsung's internal board

## 6.0 REGISTER VALUE

### 6.1 OCR Register

The 32-bit operation conditions register stores the VDD voltage profile of the eMMC. In addition, this register includes a status information bit. This status bit is set if the eMMC power up procedure has been finished. The OCR register shall be implemented by all eMMCs.

[Table 14] OCR Register

OCR bit	VDD voltage window <sup>2</sup>	Register Value
[6:0]	Reserved	00 00000b
[7]	1.70 - 1.95	1b
[14:8]	2.0-2.6	000 0000b
[23:15]	2.7-3.6	1 1111 1111b
[28:24]	Reserved	0 0000b
[30:29]	Access Mode	00b (byte mode) 10b (sector mode) -[*Higher than 2GB only]
[31]	eMMC power up status bit (busy) <sup>1</sup>	

**NOTE :**

- 1) This bit is set to LOW if the eMMC has not finished the power up routine
- 2) The voltage for internal flash memory(VDDF) should be 2.7-3.6v regardless of OCR Register value.

### 6.2 CID Register

[Table 15] CID Register

Name	Field	Width	CID-slice	CID Value
Manufacturer ID	MID	8	[127:120]	0x15
Reserved		6	[119:114]	---
Card/BGA	CBX	2	[113:112]	01
OEM/Application ID	OID	8	[111:104]	... <sub>1</sub>
Product name	PNM	48	[103:56]	See Product name table
Product revision	PRV	8	[55:48]	... <sub>2</sub>
Product serial number	PSN	32	[47:16]	... <sub>3</sub>
Manufacturing date	MDT	8	[15:8]	... <sub>4</sub>
CRC7 checksum	CRC	7	[7:1]	... <sub>5</sub>
not used, always '1'	-	1	[0:0]	---

**NOTE :**

- 1),4),5) description are same as eMMC JEDEC standard
- 2) PRV is composed of the revision count of controller and the revision count of F/W patch
- 3) A 32 bits unsigned binary integer. (Random Number)

#### 6.2.1 Product name table (In CID Register)

[Table 16] Product name table

Part Number	Density	Product Name in CID Register (PNM)
KLM8G1GESD-B03x	8 GB	0 x 384753443352
KLMAG2GESD-B03x	16 GB	0 x 414753443352
KLMBG4GESD-B03x	32 GB	0 x 424753443352
KLMSG8GESD-B03x	64 GB	0 x 434753443352

**IF THERE IS ANY OTHER OPERATION TO IMPLEMENT IN ADDITION TO SPECIFICATION IN THE DATASHEET OR JEDEC STANDARD, PLEASE CONTACT EACH BRANCH OFFICE OR HEADQUARTERS OF SAMSUNG ELECTRONICS.**

### 6.3 CSD Register

The Card-Specific Data register provides information on how to access the eMMC contents. The CSD defines the data format, error correction type, maximum data access time, data transfer speed, whether the DSR register can be used etc. The programmable part of the register (entries marked by W or E, see below) can be changed by CMD27. The type of the entries in the table below is coded as follows:

R : Read only

W: One time programmable and not readable.

R/W: One time programmable and readable.

W/E : Multiple writable with value kept after power failure, H/W reset assertion and any CMD0 reset and not readable.

R/W/E: Multiple writable with value kept after power failure, H/W reset assertion and any CMD0 reset and readable.

R/W/C\_P: Writable after value cleared by power failure and HW/ rest assertion (the value not cleared by CMD0 reset) and readable.

R/W/E\_P: Multiple writable with value reset after power failure, H/W reset assertion and any CMD0 reset and readable.

W/E/\_P: Multiple writable with value reset after power failure, H/W reset assertion and any CMD0 reset and not readable.

[Table 17] CSD Register

Name	Field	Width	Cell Type	CSD-slice	CSD Value			
					8 GB	16 GB	32 GB	64 GB
CSD structure	CSD_STRUCTURE	2	R	[127:126]	0x03			
System specification version	SPEC_VERS	4	R	[125:122]	0x04			
Reserved	-	2	R	[121:120]	-			
Data read access-time 1	TAAC	8	R	[119:112]	0x27			
Data read access-time 2 in CLK cycles (NSAC*100)	NSAC	8	R	[111:104]	0x01			
Max. bus clock frequency	TRAN_SPEED	8	R	[103:96]	0x32			
Device command classes	CCC	12	R	[95:84]	0xF5			
Max. read data block length	READ_BL_LEN	4	R	[83:80]	0x09			
Partial blocks for read allowed	READ_BL_PARTIAL	1	R	[79:79]	0x00			
Write block misalignment	WRITE_BLK_MISALIGN	1	R	[78:78]	0x00			
Read block misalignment	READ_BLK_MISALIGN	1	R	[77:77]	0x00			
DSR implemented	DSR_IMP	1	R	[76:76]	0x00			
Reserved	-	2	R	[75:74]	-			
Device size	C_SIZE	12	R	[73:62]	0xFFFF			
Max. read current @ VDD min	VDD_R_CURR_MIN	3	R	[61:59]	0x06			
Max. read current @ VDD max	VDD_R_CURR_MAX	3	R	[58:56]	0x06			
Max. write current @ VDD min	VDD_W_CURR_MIN	3	R	[55:53]	0x06			
Max. write current @ VDD max	VDD_W_CURR_MAX	3	R	[52:50]	0x06			
Device size multiplier	C_SIZE_MULT	3	R	[49:47]	0x07			
Erase group size	ERASE_GRP_SIZE	5	R	[46:42]	0x1F			
Erase group size multiplier	ERASE_GRP_MULT	5	R	[41:37]	0x1F			
Write protect group size	WP_GRP_SIZE	5	R	[36:32]	0x0F			
Write protect group enable	WP_GRP_ENABLE	1	R	[31:31]	0x01			
Manufacturer default ECC	DEFAULT_ECC	2	R	[30:29]	0x00			
Write speed factor	R2W_FACTOR	3	R	[28:26]	0x03			
Max. write data block length	WRITE_BL_LEN	4	R	[25:22]	0x09			
Partial blocks for write allowed	WRITE_BL_PARTIAL	1	R	[21:21]	0x00			
Reserved	-	4	R	[20:17]	-			
Content protection application	CONTENT_PROT_APP	1	R	[16:16]	0x00			
File format group	FILE_FORMAT_GRP	1	R/W	[15:15]	0x00			
Copy flag (OTP)	COPY	1	R/W	[14:14]	0x01			
Permanent write protection	PERM_WRITE_PROTECT	1	R/W	[13:13]	0x00			
Temporary write protection	TMP_WRITE_PROTECT	1	R/W/E	[12:12]	0x00			
File format	FILE_FORMAT	2	R/W	[11:10]	0x00			
ECC code	ECC	2	R/W/E	[9:8]	0x00			
CRC	CRC	7	R/W/E	[7:1]	-			
Not used, always '1'	-	1	—	[0:0]	-			

**IF THERE IS ANY OTHER OPERATION TO IMPLEMENT IN ADDITION TO SPECIFICATION IN THE DATASHEET OR JEDEC STANDARD, PLEASE CONTACT EACH BRANCH OFFICE OR HEADQUARTERS OF SAMSUNG ELECTRONICS.**

## 6.4 Extended CSD Register

The Extended CSD register defines the eMMC properties and selected modes. It is 512 bytes long.

The most significant 320 bytes are the Properties segment, which defines the eMMC capabilities and cannot be modified by the host. The lower 192 bytes are the Modes segment, which defines the configuration the eMMC is working in. These modes can be changed by the host by means of the SWITCH command.

R : Read only

W: One time programmable and not readable.

R/W: One time programmable and readable.

W/E : Multiple writable with value kept after power failure, H/W reset assertion and any CMD0 reset and not readable.

R/W/E: Multiple writable with value kept after power failure, H/W reset assertion and any CMD0 reset and readable.

R/W/C\_P: Writable after value cleared by power failure and HW/ rest assertion (the value not cleared by CMD0 reset) and readable.

R/W/E\_P: Multiple writable with value reset after power failure, H/W reset assertion and any CMD0 reset and readable.

W/E/\_P: Multiple writable with value reset after power failure, H/W reset assertion and any CMD0 reset and not readable

[Table 18] Extended CSD Register

Name	Field	Size (Bytes)	Cell Type	CSD-slice	CSD Value			
					8 GB	16 GB	32 GB	64 GB
Properties Segment								
Reserved <sup>1</sup>		6	-	[511:506]	-			
Extended Security Commands Error	EXT_SECURITY_ERR	1	R	[505]	0x00			
Supported Command Sets	S_CMD_SET	1	R	[504]	0x01			
HPI features	HPI_FEATURES	1	R	[503]	0x01			
Background operations support	BKOPS_SUPPORT	1	R	[502]	0x01			
Max packed read commands	MAX_PACKED_READS	1	R	[501]	0x3F			
Max packed write commands	MAX_PACKED_WRITES	1	R	[500]	0x3F			
Data Tag Support	DATA_TAG_SUPPORT	1	R	[499]	0x01			
Tag Unit Size	TAG_UNIT_SIZE	1	R	[498]	0x04			
Tag Resources Size	TAG_RES_SIZE	1	R	[497]	0x00			
Context management capabilities	CONTEXT_CAPABILITIES	1	R	[496]	0x05			
Large Unit size	LARGE_UNIT_SIZE_M1	1	R	[495]	0x07			
Extended partitions attribute support	EXT_SUPPORT	1	R	[494]	0x03			
Supported modes	SUPPORTED_MODES	1	R	[493]	0x01			
FFU features	FFU_FEATURES	1	R	[492]	0x00			
Operation codes timeout	OPERATION_CODE_TIMEOUT	1	R	[491]	0x00			
FFU Argument	FFU_ARG	4	R	[490:487]	0xC7810000			
Reserved <sup>1</sup>		181	-	[486:306]	-			
Number of FW sectors correctly programmed	NUMBER_OF_FW_SECTORS_CORRECTLY_PROGRAMMED	4	R	[305:302]	0x00			
Vendor proprietary health report	VENDOR_PROPRIETARY_HEALTH_REPORT	32	R	[301:270]	0x00			
Device life time estimation type B	DEVICE_LIFE_TIME_EST_TYP_B	1	R	[269]	0x01			
Device life time estimation type A	DEVICE_LIFE_TIME_EST_TYP_A	1	R	[268]	0x01			
Pre EOL information	PRE_EOL_INFO	1	R	[267]	0x01			
Optimal read size	OPTIMAL_READ_SIZE	1	R	[266]	0x00			
Optimal write size	OPTIMAL_WRITE_SIZE	1	R	[265]	0x08	0x10	0x20	
Optimal trim unit size	OPTIMAL_TRIM_UNIT_SIZE	1	R	[264]	0x01			
Device version	DEVICE_VERSION	2	R	[263:262]	0x00			
Firmware version	FIRMWARE_VERSION	3	R	[261:254]	FW Patch Ver.			
Power class for 200MHz, DDR at VCC=3.6V	PWR_CL_DDR_200_360	1	R	[253]	0x00			
Cache size	CACHE_SIZE	4	R	[252:249]	0x10000			

**IF THERE IS ANY OTHER OPERATION TO IMPLEMENT IN ADDITION TO SPECIFICATION IN THE DATASHEET OR JEDEC STANDARD, PLEASE CONTACT EACH BRANCH OFFICE OR HEADQUARTERS OF SAMSUNG ELECTRONICS.**

Generic CMD6 timeout	GENERIC_CMD6_TIME	1	R	[248]	0x0A			
Power off notification(long) timeout	POWER_OFF_LONG_TIME	1	R	[247]	0x3C			
Background operations status	BKOPS_STATUS	1	R	[246]	0x00			
Number of correctly programmed sectors	CORRECTLY_PRG_SECTORS_NUM	4	R	[245:242]	0x00			
1st initialization time after partitioning	INI_TIMEOUT_AP	1	R	[241]	0x1E			
Reserved <sup>1</sup>		1	-	[240]	-			
Power class for 52MHz, DDR at 3.6V	PWR_CL_DDR_52_360	1	R	[239]	0x00			
Power class for 52MHz, DDR at 1.95V	PWR_CL_DDR_52_195	1	R	[238]	0x00			
Power class for 200MHz at Vccq=1.95V, Vcc=3.6V	PWR_CL_200_360	1	R	[237]	0x00			
Power class for 200MHz, at Vccq=1.3V, Vcc=3.6V	PWR_CL_200_195	1	R	[236]	0x00			
Minimum Write Performance for 8bit at 52MHz in DDR mode	MIN_PERF_DDR_W_8_52	1	R	[235]	0x00			
Minimum Read Performance for 8bit at 52MHz in DDR mode	MIN_PERF_DDR_R_8_52	1	R	[234]	0x00			
Reserved <sup>1</sup>		1	-	[233]	-			
TRIM Multiplier	TRIM_MULT	1	R	[232]	0x02			
Secure Feature support	SEC_FEATURE_SUPPORT	1	R	[231]	0x55			
Secure Erase Multiplier	SEC_ERASE_MULT	1	R	[230]	0x1B			
Secure TRIM Multiplier	SEC_TRIM_MULT	1	R	[229]	0x11			
Boot information	BOOT_INFO	1	R	[228]	0x07			
Reserved <sup>1</sup>		1	-	[227]	-			
Boot partition size	BOOT_SIZE_MULT	1	R	[226]	0x80			
Access size	ACC_SIZE	1	R	[225]	0x07			
High-capacity erase unit size	HC_ERASE_GRP_SIZE	1	R	[224]	0x01			
High-capacity erase timeout	ERASE_TIMEOUT_MULT	1	R	[223]	0x01			
Reliable write sector count	REL_WR_SEC_C	1	R	[222]	0x01			
High-capacity write protect group size	HC_WP_GRP_SIZE	1	R	[221]	0x10			
Sleep current (VCC)	S_C_VCC	1	R	[220]	0x07			
Sleep current (VCCQ)	S_C_VCCQ	1	R	[219]	0x07			
Production state awareness timeout	PRODUCTION_STATE_AWARENESS_TIMEOUT	1	R	[218]	0x00			
Sleep/awake timeout	S_A_TIMEOUT	1	R	[217]	0x11			
Sleep Notification Timeout	SLEEP_NOTIFICATION_TIME	1	R	[216]	0x07			
Sector Count	SEC_COUNT	4	R	[215:212]	0xE900 00	0x1D1F 000	0x3A3E 000	0x0747 C000
Reserved <sup>1</sup>		1	-	[211]	-			
Minimum Write Performance for 8bit at 52MHz	MIN_PERF_W_8_52	1	R	[210]	0x00			
Minimum Read Performance for 8bit at 52MHz	MIN_PERF_R_8_52	1	R	[209]	0x00			
Minimum Write Performance for 8bit at 26MHz, for 4bit at 52MHz	MIN_PERF_W_8_26_4_52	1	R	[208]	0x00			
Minimum Read Performance for 8bit at 26MHz, for 4bit at 52MHz	MIN_PERF_R_8_26_4_52	1	R	[207]	0x00			
Minimum Write Performance for 4bit at 26MHz	MIN_PERF_W_4_26	1	R	[206]	0x00			
Minimum Read Performance for 4bit at 26MHz	MIN_PERF_R_4_26	1	R	[205]	0x00			
Reserved <sup>1</sup>		1	-	[204]	-			
Power class for 26MHz at 3.6V 1 R	PWR_CL_26_360	1	R	[203]	0x00			

IF THERE IS ANY OTHER OPERATION TO IMPLEMENT IN ADDITION TO SPECIFICATION IN THE DATASHEET OR JEDEC STANDARD, PLEASE CONTACT EACH BRANCH OFFICE OR HEADQUARTERS OF SAMSUNG ELECTRONICS.



Power class for 52MHz at 3.6V 1 R	PWR_CL_52_360	1	R	[202]	0x00	
Power class for 26MHz at 1.95V 1 R	PWR_CL_26_195	1	R	[201]	0x00	
Power class for 52MHz at 1.95V 1 R	PWR_CL_52_195	1	R	[200]	0x00	
Partition switching timing	PARTITION_SWITCH_TIME	1	R	[199]	0x01	
Out-of-interrupt busy timing	OUT_OF_INTERRUPT_TIME	1	R	[198]	0x02	
I/O Driver Strength	DRIVER_STRENGTH	1	R	[197]	0x1F	
Device type	DEVICE_TYPE	1	R	[196]	0x57	
Reserved <sup>1</sup>		1	-	[195]	-	
CSD structure	CSD_STRUCTURE	1	R	[194]	0x02	
Reserved <sup>1</sup>		1	-	[193]	-	
Extended CSD revision	EXT_CSD_REV	1	R	[192]	0x07	
Modes Segment						
Command set	CMD_SET	1	R/W/E_P	[191]	0x00	
Reserved <sup>1</sup>		1	-	[190]	-	
Command set revision	CMD_SET_REV	1	R	[189]	0x00	
Reserved <sup>1</sup>		1	-	[188]	-	
Power class	POWER_CLASS	1	R/W/E_P	[187]	0x00	
Reserved <sup>1</sup>		1	-	[186]	-	
High-speed interface timing	HS_TIMING	1	R/W/E_P	[185]	0x00	
Reserved <sup>1</sup>		1	-	[184]	-	
Bus width mode	BUS_WIDTH	1	W/E_P	[183]	0x00	
Reserved <sup>1</sup>		1	-	[182]	-	
Erased memory content	ERASED_MEM_CONT	1	R	[181]	0x00	
Reserved <sup>1</sup>		1	-	[180]	-	
Partition configuration	PARTITION_CONFIG	1	R/W/E & R/W/E_P	[179]	0x00	
Boot config protection	BOOT_CONFIG_PROT	1	R/W & R/W/C_P	[178]	0x00	
Boot bus Conditions	BOOT_BUS_CONDITIONS	1	R/W/E	[177]	0x00	
Reserved <sup>1</sup>		1	-	[176]	-	
High-density erase group definition	ERASE_GROUP_DEF	1	R/W/E_P	[175]	0x00	
Boot write protection status registers	BOOT_WP_STATUS	1	R	[174]	0x00	
Boot area write protection register	BOOT_WP	1	R/W & R/W/C_P	[173]	0x00	
Reserved <sup>1</sup>		1	-	[172]	-	
User area write protection register	USER_WP	1	R/W, R/W/C_P &R/W/ E_P	[171]	0x00	
Reserved <sup>1</sup>		1	-	[170]	-	
FW configuration	FW_CONFIG	1	R/W	[169]	0x00	
RPMB Size	RPMB_SIZE_MULT	1	R	[168]	0x04	0x20
Write reliability setting register	WR_REL_SET	1	R/W	[167]	0x1F	
Write reliability parameter register	WR_REL_PARAM	1	R	[166]	0x14	
Start Sanitize operation	SANITIZE_START	1	W/E_P	[165]	0x00	
Manually start background operations	BKOPS_START	1	W/E_P	[164]	0x00	
Enable background operations handshake	BKOPS_EN	1	R/W	[163]	0x00	
H/W reset function	RST_n_FUNCTION	1	R/W	[162]	0x00	
HPI management	HPI_MGMT	1	R/W/E_P	[161]	0x00	

**IF THERE IS ANY OTHER OPERATION TO IMPLEMENT IN ADDITION TO SPECIFICATION IN THE DATASHEET OR JEDEC STANDARD, PLEASE CONTACT EACH BRANCH OFFICE OR HEADQUARTERS OF SAMSUNG ELECTRONICS.**



Partitioning Support	PARTITIONING_SUPPORT	1	R	[160]	0x07		
Max Enhanced Area Size	MAX_ENH_SIZE_MULT	3	R	[159:157]	0x1D2	0x3A3	0x747
Partitions attribute	PARTITIONS_ATTRIBUTE	1	R/W	[156]	0x00		
Partitioning Setting	PARTITION_SETTING_COMPLETED	1	R/W	[155]	0x00		
General Purpose Partition Size	GP_SIZE_MULT	12	R/W	[154:143]	0x00		
Enhanced User Data Area Size	ENH_SIZE_MULT	3	R/W	[142:140]	0x00		
Enhanced User Data Start Address	ENH_START_ADDR	4	R/W	[139:136]	0x00		
Reserved <sup>1</sup>		1	-	[135]	-		
Bad Block Management mode	SEC_BAD_BLK_MGMNT	1	R/W	[134]	0x00		
Production state awareness	PRODUCTION_STATE_AWARENESS	1	W/E_P	[133]	0x00		
Package Case Temperature is controlled	TCASE_SUPPORT	1	W/E_P	[132]	0x00		
Periodic Wake-up	PERIODIC_WAKEUP	1	R/W/E	[131]	0x00		
Program CID/CSD in DDR mode support	PROGRAM_CID_CSD_DDR_SUPPORT	1	R	[130]	0x01		
Reserved <sup>1</sup>		2	-	[129:128]	-		
Vendor Specific Fields	VENDOR_SPECIFIC_FIELD	64	<vendor specific>	[127:64]	-		
Native sector size	NATIVE_SECTOR_SIZE	1	R	[63]	0x00		
Sector size emulation	USE_NATIVE_SECTOR	1	R/W	[62]	0x00		
Sector size	DATA_SECTOR_SIZE	1	R	[61]	0x00		
1st initialization after disabling sector size emulation	INI_TIMEOUT_EMU	1	R	[60]	0x00		
Class 6 commands control	CLASS_6_CTRL	1	R/W/E_P	[59]	0x00		
Number of addressed group to be Released	DYNCAP_NEEDED	1	R	[58]	0x00		
Exception events control	EXCEPTION_EVENTS_CTRL	2	R/W/E_P	[57:56]	0x00		
Exception events status	EXCEPTION_EVENTS_STATUS	2	R	[55:54]	0x00		
Extended Partitions Attribute	EXT_PARTITIONS_ATTRIBUTE	2	R/W	[53:52]	0x00		
Context configuration	CONTEXT_CONF	15	R/W/E_P	[51:37]	0x00		
Packed command status	PACKED_COMMAND_STATUS	1	R	[36]	0x00		
Packed command failure index	PACKED_FAILURE_INDEX	1	R	[35]	0x00		
Power Off Notification	POWER_OFF_NOTIFICATION	1	R/W/E_P	[34]	0x00		
Control to turn the Cache ON/OFF	CACHE_CTRL	1	R/W/E_P	[33]	0x00		
Flushing of the cache	FLUSH_CACHE	1	W/E_P	[32]	0x00		
Reserved <sup>1</sup>		1	-	[31]	-		
Mode config	MODE_CONFIG	1	R/W/E_P	[30]	0x00		
Mode operation codes	MODE_OPERATION_CODES	1	W/E_P	[29]	0x00		
Reserved <sup>1</sup>		2	-	[28:27]	-		
FFU status	FFU_STATUS	1	R	[26]	0x00		
Pre loading data size	PRE_LOADING_DATA_SIZE	4	R/W/E_P	[25:22]	0x00		
Max pre loading data size	MAX_PRE_LOADING_DATA_SIZE	4	R	[21:18]	0x00		
Product state awareness enablement	PRODUCT_STATE_AWARENESS_ENABLEMENT	1	R/W/E & R	[17]	0x00		
Secure Removal Type	SECURE_REMOVAL_TYPE	1	R/W & R	[16]	0x09		
Reserved <sup>1</sup>		16	-	[15:0]	-		

## NOTE :

1) Reserved bits should read as "0."

**IF THERE IS ANY OTHER OPERATION TO IMPLEMENT IN ADDITION TO SPECIFICATION IN THE DATASHEET OR JEDEC STANDARD, PLEASE CONTACT EACH BRANCH OFFICE OR HEADQUARTERS OF SAMSUNG ELECTRONICS.**

## 7.0 AC PARAMETER

### 7.1 Timing Parameter

[Table 19] Timing Parameter

Timing Parameter		Max. Value	Unit
Initialization Time (tINIT)	Normal <sup>1)</sup>	200	ms
	After partition setting <sup>2)</sup>	3	s
Read Timeout		100	ms
Write Timeout		350	ms
Erase Timeout		20	ms
Force Erase Timeout		3	min
Secure Erase Timeout		8	s
Secure Trim step1 Timeout		5	s
Secure Trim step2 Timeout		3	s
Trim Timeout		600	ms
Partition Switching Timeout (after Init)		1	ms
Power Off Notification (Short) Timeout		20	ms
Power Off Notification (Long) Timeout		600	ms

**NOTE :**

- 1) Normal Initialization Time without partition setting
- 2) Initialization Time after partition setting, refer to INI\_TIMEOUT\_AP in 6.4 EXT\_CSD register.  
This Initialization Time for partition setting operates once in the first place during lifetime.
- 3) Be advised Timeout Values specified in Table above are for testing purposes under Samsung test pattern only and actual timeout situations may vary
- 4) EXCEPTION\_EVENT may occur and the actual timeout values may vary due to user environment

### 7.2 Previous Bus Timing Parameters for DDR52 and HS200 mode are defined by JEDEC standard

### 7.3 Bus Timing Specification in HS400 mode

#### 7.3.1 HS400 Device Input Timing

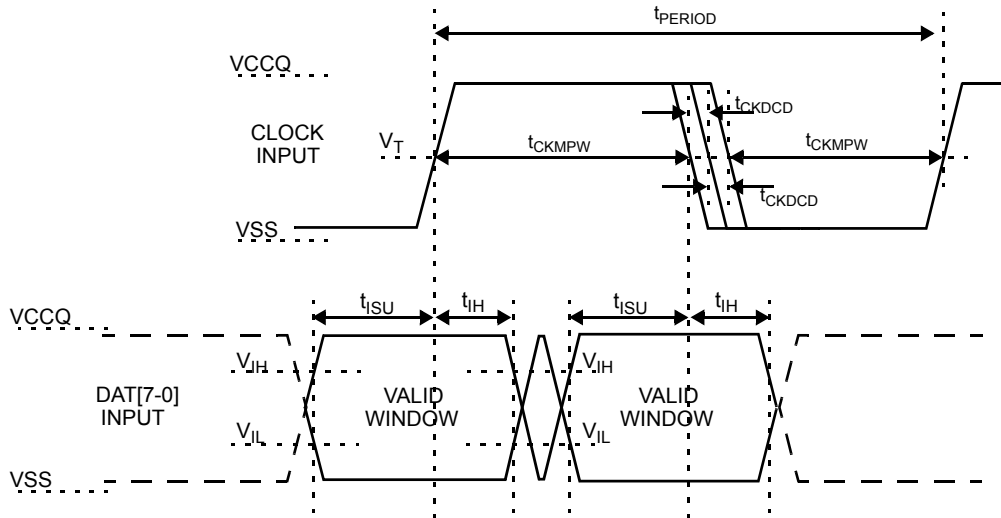

[Figure 7] HS400 Device Input Timing

**NOTE :**

- 1)  $t_{ISU}$  and  $t_{IH}$  are measured at  $V_{IL}(\text{max.})$  and  $V_{IH}(\text{min.})$ .
- 2)  $V_{IH}$  denotes  $V_{IH}(\text{min.})$  and  $V_{IL}$  denotes  $V_{IL}(\text{max.})$

[Table 20] HS400 Device input timing

Parameter	Symbol	Min	Max	Unit
Input CLK				
Cycle time data transfer mode	$t_{PERIOD}$	5	-	-
Slew rate	SR	1.125	-	V/ns
Duty cycle distortion	$t_{CKDCD}$	0.0	0.3	ns
Minimum pulse width	$t_{CKMPW}$	2.2	-	ns
Input DAT (referenced to CLK)				
Input set-up time	$t_{ISUddr}$	0.4	-	ns
Input hold time	$t_{IHddr}$	0.4	-	ns
Slew rate	SR	1.125	-	V/ns

IF THERE IS ANY OTHER OPERATION TO IMPLEMENT IN ADDITION TO SPECIFICATION IN THE DATASHEET OR JEDEC STANDARD, PLEASE CONTACT EACH BRANCH OFFICE OR HEADQUARTERS OF SAMSUNG ELECTRONICS.

7.3.2 HS400 Device Output Timing

Data Strobe is used to read data (data read and CRC status response read) in HS400 mode. The device output value of Data Strobe is “High-Z” when the device is not in outputting data(data read, CRC status response). Data Strobe is toggled only during data read period.

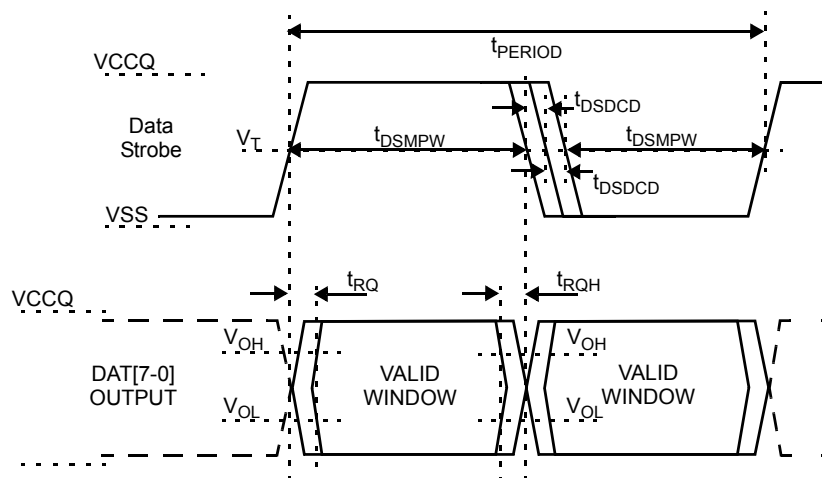

[Figure 8] HS400 Device Output Timing

NOTE :  
 $V_{OH}$  denotes  $V_{OH(min.)}$  and  $V_{OL}$  denotes  $V_{OL(max.)}$ .

[Table 21] HS400 Device Output timing

Parameter	Symbol	Min	Max	Unit
Data Strobe				
Cycle time data transfer mode	$t_{PERIOD}$	5	-	
Slew rate	SR	1.125	-	V/ns
Duty cycle distortion	$t_{DSDCD}$	0.0	0.2	ns
Minimum pulse width	$t_{DSMPW}$	2.0	-	ns
Read pre-amble	$t_{RPRE}$	0.4	-	$t_{PERIOD}$
Read post-amble	$t_{RPST}$	0.4	-	$t_{PERIOD}$
Output DAT (referenced to Data Strobe)				
Output skew	$t_{RQ}$	-	0.4	ns
Output hold skew	$t_{RQH}$	-	0.4	ns
Slew rate	SR	1.125	-	V/ns

IF THERE IS ANY OTHER OPERATION TO IMPLEMENT IN ADDITION TO SPECIFICATION IN THE DATASHEET OR JEDEC STANDARD, PLEASE CONTACT EACH BRANCH OFFICE OR HEADQUARTERS OF SAMSUNG ELECTRONICS.

## 7.4 Bus signal levels

As the bus can be supplied with a variable supply voltage, all signal levels are related to the supply voltage.

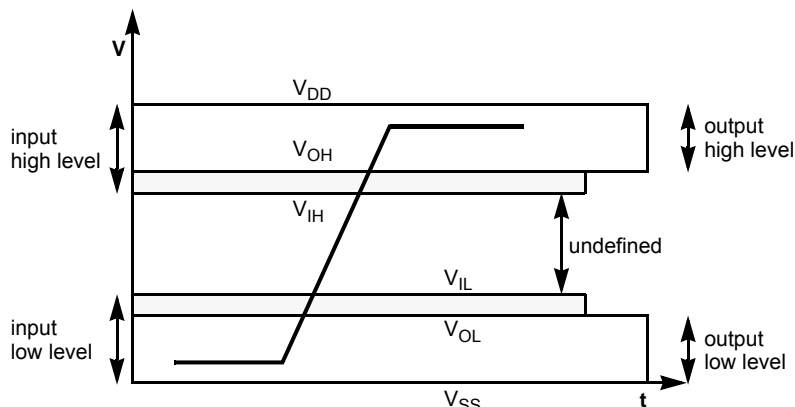

### 7.4.1 Open-drain mode bus signal level

[Table 22] Open-drain bus signal level

Parameter	Symbol	Min	Max.	Unit	Conditions
Output HIGH voltage	$V_{OH}$	$V_{DD} - 0.2$	-	V	1)
Output LOW voltage	$V_{OL}$	-	0.3	V	$I_{OL} = 2 \text{ mA}$

**NOTE :**

1) Because  $V_{oh}$  depends on external resistance value (including outside the package), this value does not apply as device specification. Host is responsible to choose the external pull-up and open drain resistance value to meet  $V_{oh}$  Min value.

### 7.4.2 Push-pull mode bus signal level eMMC

The device input and output voltages shall be within the following specified ranges for any  $V_{DD}$  of the allowed voltage range

[Table 23] Push-pull signal level—high-voltage eMMC

Parameter	Symbol	Min	Max.	Unit	Conditions
Output HIGH voltage	$V_{OH}$	$0.75 \cdot V_{CCQ}$	-	V	$I_{OH} = -100 \text{ uA} @ V_{CCQ} \text{ min}$
Output LOW voltage	$V_{OL}$	-	$0.125 \cdot V_{CCQ}$	V	$I_{OL} = 100 \text{ uA} @ V_{CCQ} \text{ min}$
Input HIGH voltage	$V_{IH}$	$0.625 \cdot V_{CCQ}$	$V_{CCQ} + 0.3$	V	-
Input LOW voltage	$V_{IL}$	$V_{SS} - 0.3$	$0.25 \cdot V_{CCQ}$	V	-

[Table 24] Push-pull signal level—1.70 - 1.95  $V_{CCQ}$  voltage Range

Parameter	Symbol	Min	Max.	Unit	Conditions
Output HIGH voltage	$V_{OH}$	$V_{CCQ} - 0.45\text{V}$	-	V	$I_{OH} = -2\text{mA}$
Output LOW voltage	$V_{OL}$	-	0.45V	V	$I_{OL} = 2\text{mA}$
Input HIGH voltage	$V_{IH}$	$0.65 \cdot V_{CCQ}$ <sup>1)</sup>	$V_{CCQ} + 0.3$	V	-
Input LOW voltage	$V_{IL}$	$V_{SS} - 0.3$	$0.35 \cdot V_{CCQ}$ <sup>2)</sup>	V	-

**NOTE :**

1)  $0.7 \cdot V_{CCQ}$  for MMC4.3 and older revisions.

2)  $0.3 \cdot V_{CCQ}$  for MMC4.3 and older revisions.

**IF THERE IS ANY OTHER OPERATION TO IMPLEMENT IN ADDITION TO SPECIFICATION IN THE DATASHEET OR JEDEC STANDARD, PLEASE CONTACT EACH BRANCH OFFICE OR HEADQUARTERS OF SAMSUNG ELECTRONICS.**

## 8.0 DC PARAMETER

### 8.1 Active Power Consumption during operation

[Table 25] Active Power Consumption during operation

Density	NAND Type	CTRL	NAND	Unit
8 GB	64 Gb MLC x1	200	50	mA
16 GB	64 Gb MLC x2		100	
32 GB	64 Gb MLC x4		200	
64 GB	64 Gb MLC x8			

\* Power Measurement conditions: Bus configuration =x8 @200MHz DDR

\* The measurement for max RMS current is the average RMS current consumption over a period of 100ms.

### 8.2 Standby Power Consumption in auto power saving mode and standby state.

[Table 26] Standby Power Consumption in auto power saving mode and standby state

Density	NAND Type	CTRL		NAND		Unit
		25°C(Typ)	85°C	25°C(Typ)	85°C	
8 GB	64 Gb MLC x1	200	1000	40	85	uA
16 GB	64 Gb MLC x2			50	135	
32 GB	64 Gb MLC x4			70	235	
64 GB	64 Gb MLC x8			130	145	

**NOTE :**

Power Measurement conditions: Bus configuration =x8, No CLK

\*Typical value is measured at Vcc=3.3V, TA=25°C. Not 100% tested.

### 8.3 Sleep Power Consumption in Sleep State

[Table 27] Sleep Power Consumption in Sleep State

Density	NAND Type	CTRL		NAND	Unit
		25°C(Typ)	85°C		
8 GB	64 Gb MLC x1	200	1000	0 <sup>1)</sup>	uA
16 GB	64 Gb MLC x2				
32 GB	64 Gb MLC x4				
64 GB	64 Gb MLC x8				

**NOTE :**

Power Measurement conditions: Bus configuration =x8, No CLK

1) In auto power saving mode , NAND power can not be turned off .However in sleep mode NAND power can be turned off. If NAND power is alive , NAND power is same with that of the Standby state.

### 8.4 Supply Voltage

[Table 28] Supply voltage

Item	Min	Max	Unit
V <sub>DD</sub> (V <sub>CCQ</sub> )	1.70 (2.7)	1.95 (3.6)	V
V <sub>DDF</sub> (V <sub>CC</sub> )	2.7	3.6	V
V <sub>SS</sub>	-0.5	0.5	V

IF THERE IS ANY OTHER OPERATION TO IMPLEMENT IN ADDITION TO SPECIFICATION IN THE DATASHEET OR JEDEC STANDARD, PLEASE CONTACT EACH BRANCH OFFICE OR HEADQUARTERS OF SAMSUNG ELECTRONICS.

## 8.5 Bus Signal Line Load

The total capacitance  $C_L$  of each line of the eMMC bus is the sum of the bus master capacitance  $C_{HOST}$ , the bus capacitance  $C_{BUS}$  itself and the capacitance  $C_{DEVICE}$  of the eMMC connected to this line:

$$C_L = C_{HOST} + C_{BUS} + C_{DEVICE}$$

The sum of the host and bus capacitances should be under 20pF.

[Table 29] Bus Signal Line Load

Parameter	Symbol	Min	Typ.	Max	Unit	Remark
Pull-up resistance for CMD	$R_{CMD}$	4.7		100	KOhm	to prevent bus floating
Pull-up resistance for DAT0-DAT7	$R_{DAT}$	10		100	KOhm	to prevent bus floating
Internal pull up resistance DAT1-DAT7	$R_{int}$	10		150	KOhm	to prevent unconnected lines floating
Single Device capacitance	$C_{DEVICE}$			12	pF	
Maximum signal line inductance				16	nH	$f_{pp} \leq 52$ MHz

[Table 30] Capacitance and Resistance for HS400 mode

Parameter	Symbol	Min	Typ	Max	Unit	Remark
Bus signal line capacitance	CL			13	pF	Single Device
Single Device capacitance	$C_{DEVICE}$			6	pF	
Pull-down resistance for Data Strobe	$R_{Data\ Strobe}$	10		100	KOhm	